



Scan to know paper details and  
author's profile

# Enhancing Energy Efficiency and Convenience with an Automated Room Light Control System

*Izang, A.A., Ajayi, O.F., Kolade, Z.A., Takon, E.W. & Oluka, B  
Babcock University*

## ABSTRACT

This paper presents the implementation of a system that controls light automatically and it is energy efficient as it only switches on the lights when required and switches them off when not needed, reducing energy consumption. Furthermore, from past study, it was noticed that most physically challenged people and most aged people do not even have the strength to switch on and off the lights as a result of the inability to manually operate the system.

For this research the ESP-32 microcontroller which is the heart of the system was used, it is programmed to receive signals from the PIR sensor and switch the lights on when it detects movement in the room. The system is also designed to switch off the lights automatically when no movement is detected for a predefined time period. The light control of the system is actualized when an individual enters and remains off after leaving. The designed system is achieved using infrared light sensor and combination of array counters. The implemented system can be commercialized to be used in public places like malls or libraries to restrict the flow of people.

**Keywords:** ESP-32 microcontroller, sensor, room light controller system, ESP-NOW, energy efficiency, smart home, energy conservation, wireless communication.

**Classification:** LCC Code: TK5105.8857

**Language:** English



Great Britain  
Journals Press

LJP Copyright ID: 975832  
Print ISSN: 2514-863X  
Online ISSN: 2514-8648

London Journal of Research in Computer Science and Technology

Volume 23 | Issue 3 | Compilation 1.0





# Enhancing Energy Efficiency and Convenience with an Automated Room Light Control System

Izang, A.A.<sup>α</sup>, Ajayi, O.F.<sup>σ</sup>, Kolade, Z.A.<sup>ρ</sup>, Takon, E.W.<sup>ω</sup> & Oluka, B<sup>✶</sup>

**Author α:** Department of Information Technology, School of Computing and Engineering Sciences, Babcock University, Ilishan-Remo, Ogun State, Nigeria.

**σ ρ ω ✶:** Department of Computer Science, School of Computing and Engineering Sciences, Babcock University, Ilishan-Remo, Ogun State, Nigeria.

## ABSTRACT

*This paper presents the implementation of a system that controls light automatically and it is energy efficient as it only switches on the lights when required and switches them off when not needed, reducing energy consumption.*

*Furthermore, from past study, it was noticed that most physically challenged people and most aged people do not even have the strength to switch on and off the lights as a result of the inability to manually operate the system.*

*For this research the ESP-32 microcontroller which is the heart of the system was used, it is programmed to receive signals from the PIR sensor and switch the lights on when it detects movement in the room. The system is also designed to switch off the lights automatically when no movement is detected for a predefined time period. The light control of the system is actualized when an individual enters and remains off after leaving. The designed system is achieved using infrared light sensor and combination of array counters. The implemented system can be commercialized to be used in public places like malls or libraries to restrict the flow of people.*

**Keywords:** ESP-32 microcontroller, sensor, room light controller system, ESP-NOW, energy efficiency, smart home, energy conservation, wireless communication.

## I. INTRODUCTION

Conserving electricity is important in this digital world, frequently humans have forgotten to turn off appliances around them thereby not conserving electricity. Due to this, creating an economic stimulus for their budgetary development has proven to be extremely difficult.

To overcome this there is a need to manage the lighting around us (room, halls, conference room etc.), automated systems are an efficient way to reduce energy use today. The design, development, and implementation of a micro controller-based automatic room light controller with a bidirectional counter are presented in this project. When it comes to product development, it is important to step back, assess the current situation, and conceive a sane and logical solution to the issue at hand. It is necessary to provide background information regarding the conventional method of carrying out a task.

Within our institution Babcock University, this project can be used in various rooms like seminar hall, conference hall, classrooms to count the accurate number of people in that room. This project can also be done in our homes because many times we come out of our bedroom, and we forget to turn off the room light. It can also be used in cinemas, malls etc. This automation helps in reducing cost in that no human power is required to control the system.

This system is designed to control the lighting system of the room by turning on the lights automatically whenever there are one or more

persons in the room. To display the people in the room, this system is also linked to a bidirectional visitor counter. The manner this system operates is as follows: Whenever anyone enters the room, the visitor counter is increased by one, and once someone leaves, the visitor counter is decreased by one.

Also, since the government or any institution can easily control the population in each location, this project can help to address the issue that insecurity has become to our nation. This project aims to automatically turn on or off the lights in a room by detecting the human movement hence, the research investigates an automated room light to reduce the stemming difficulty faced by multiple institutions, businesses, and governmental organizations in order to control these and the adoption of automated control in this situation would make it easier for those with disabilities and illness to operate these devices.

## II. LITERATURE REVIEW

Prior to this study, other studies have been developed to control how lights are operated. Below are the various studies and their purpose

The power usage in public places like Library, Hotels, and Domestic takes the highest percentage of the energy consumed in the world (Bai & Ku, 2008). Currently, the area of technologies focuses on; automation, energy consumption and cost optimization (Sudhakar, Anil, Ashok, & Bhaskar, 2013). Automation in the public places guarantees efficiency as well as increase in the lifespan of electrical components (Tadimeti & Pulipati, 2013).

Gazis et al. (2022) proposed monitoring and tracking visitors within a building. The authors used python, protocols, communication and sensors. Specific location operation might be the negative part of the design.

Owing to the rapid increase in population, it is also important to know the number of people in the public places by counting the inflow and outflow, this will enable the organization or administrators to satisfy the visitors, feasibility studies and future expansion (Dey *et al.*, 2016).

Human beings, especially old and disabled find it difficult to put-off light when it is not required, this results into energy wastage and increase in the cost of electricity (Ranjit, Ibrahim, Salim, & Wong, 2009). As a result of the increase in cost of electrical energy and shortcomings in our power generation, it becomes necessary to make good use of the available electrical energy (Priya & Vijayan, 2017). In (Monder, Chen, & Tomoaki, 2022), the author presented an array sensor and low-resolution infrared sensor designed to identify the location of indoor, outdoor peoples were not discussed in the paper. Therefore, energy conservation has become a priority for efficient utilization of electrical energy (Wazed, Nafis, Islam, & Sayem, 2010). Knowing the exact number of people at a particular time can be used to analyze the progress an organization is making and also guide it in policy and decision making (Ashkanani, Roza, & Naghavipour, 2015). (Manoj, & Thingom, (2022) designed and implemented Visitor counter using FPGA and Bluetooth, though the goal was achieved, but the design worked in one direction only. Infrared ray sensor was used to design visitor counters with automatic light control but absolute count would not be determined by the design.

*Automatic room light controller using IR sensor:* According to (T Jangfa in the year 2021) came up with a device that can automatically control the lighting system of a room and capability of taking count of number of people in a room on its own has been long overdue. Fire outbreaks that occur in various homes originate when the occupant is either sleeping or not even at home at all. In big environments such as petrochemical industries, whenever there is a fire outbreak, it turns out to be so fierce that people run away for the sake of their lives.

*Automatic room light controller using Arduino and pir sensor:* According to (Vrushabh Kunturwar, in the year 2020.) This review is basically talking about how the room will automatically turn on upon detecting a human motion and stay turned on until the person has left or there is no motion initially. When there is no human movement, the PIR sensor doesn't detect any person and its OUT pin stays LOW.

*Room light controller with visitor counter:* According (Thitesh Raminao in the year 2018) today's world, there is a continuous need for automatic appliances automatic room light controller with visitor counter is a reliable circuit that takes over the task of controlling the room lights as well as counting number of persons/visitors in the room very accurately." Main concept behind this project is to measure and display the number of persons entering in any room like seminar hall, conference room. And when the number of persons inside the room is zero, the power supply inside the room will be turned off. This will help to save electricity. LCD display placed outside the room displays the number of persons inside the room.

*A bidirectional automatic room light controller using visitor counter:* According to (EP Ogberohwo, in the year 2018). A bidirectional automatic room light controller using visitor counter and 8051 microcontroller is a reliable circuit that takes over the task of controlling the room light as well as counting the number of persons visiting the room very accurately. When somebody enters the room the counter is incremented by one and the light in the room will be switched ON whenever anyone leaves the room then the counter is decremented by one and so on. The light will only be switched OFF when all the persons in the room goes out.

### III. THE DESIGN AND IMPLEMENTATION OF THE SYSTEM

With the help of this research, a smart home solution, people especially physically handicapped people will have an easy and effective way to regulate a room's lighting settings since they won't need to manually turn on or off the light; instead, the light will do so on its own.

The device automatically detects changes in temperature and motion and adjusts the lighting conditions as necessary using a combination of sophisticated sensors and a microcontroller.

An AC-DC adapter or batteries can be used to power the Automated Room Light Controller in order to provide the system with the necessary

voltage and current. A boost converter would have to be installed to enhance the DC power supply and provide the components with a steady 5V supply, protecting the individual components from harm.

The ESP-32 Microcontroller is the heart of the system. It provides a map of all the hardware that is embedded in this microcontroller. A host device will enable the Wi-Fi module to connect to the internet, allowing the Wi-fi module to inform the microcontroller that is connected. There are a variety of ways to set up an ESP-NOW network. Within the same network, ESP32 and ESP8266 devices can coexist. *Initiators and Responders:*

1. *Initiator:* This device initiates the transmission. It will require the MAC address of the receiving devices.
2. *Responder:* This device receives the transmission.

Using widely used asynchronous serial communication interfaces, such as RS232, RS422, and RS485, the Universal Asynchronous Receiver/Transmitter (UART) handles communication (i.e., time constraints and data framing). A UART offers a widely used and affordable way to implement full- or half-duplex data exchange across various devices. Each of the three UART controllers (also known as ports) on the ESP32 chip uses the same set of registers, making programming easier and allowing for greater flexibility. Each UART controller is independently configurable with parameters such as baud rate, data bit length, bit ordering, number of stop bits, parity bit etc. All the controllers are compatible with UART-enabled devices from various manufacturers and can also support Infrared Data Association protocols (IrDA)

At the entrance, the motion sensor is used to identify guests. When someone enters the room, the motion sensor alerts the ESP-32. The temperature sensor is used to determine the ambient temperature of the space. The ESP-32 can alter the lighting in the room using this information. The light can be turned on and off using the motion sensor.

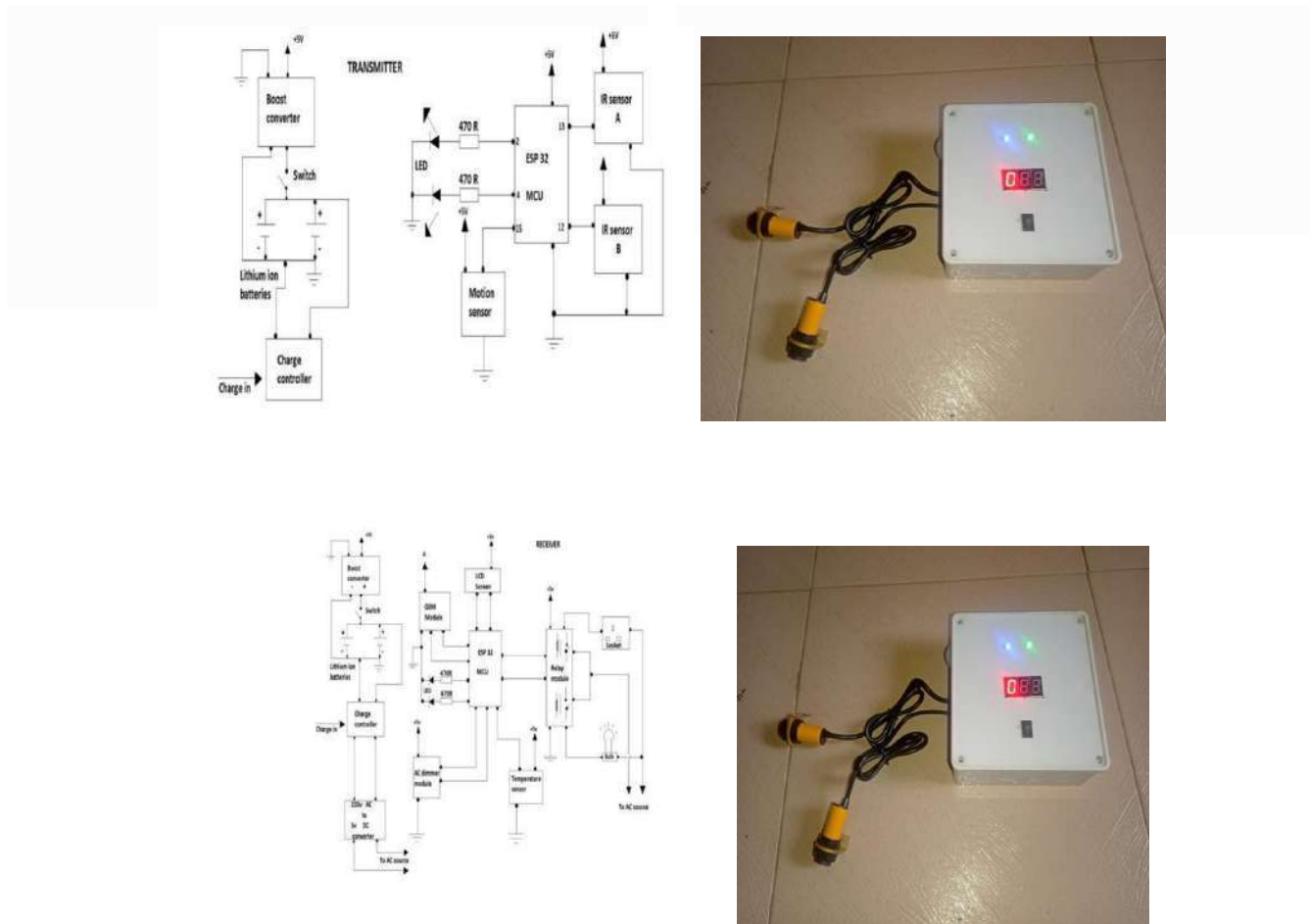

Figure 1: Schematic Diagram

The diagram above depicts how the device is carefully mounted using two boards, one for the transmitter and one for the receiver. An infrared sensor is used to count the number of visitors; the first infrared sensor starts the timer, and the second infrared sensor stops it. The first board, which is the transmitter, is carefully positioned on one perboard. We have the temperature in addition to the two lithium-ion batteries next to the perfboard. On top of the PVC shell, there is a motion sensor that can be used to identify people, and there is a seven-segment display that can count the number of persons that have been spotted.

There are two lights on top of it that you can see when you enter. The green light comes on when someone opens the door, while the blue light flashes when it is on. The second board, which is the receiver, is neatly installed on one perfboard along with the rest of the system's parts, four lithium-ion batteries, an AC-DC converter, a boost

converter for charging the batteries, a relay module, an ESP-32 microcontroller, a GSM module, and an AC dimmer.

#### IV. HOW THE SYSTEM WORKS

You must turn on the system in order to use this device, at which point the ESP-32 microcontroller initializes and begins to run the firmware. Then, to determine the ambient conditions in the room, the ESP-32 periodically checks the temperature and motion sensor data. The ESP-32 adjusts the brightness of the lights using the AC dimmer and relay module based on input from the temperature and motion sensor. To conserve energy and create a comfortable environment, the lights automatically dim if the temperature rises too much. If no one is present, the lights will be turned off.

## V. CONCLUSION AND RECOMMENDATION

This work presents the design and implementation of automatic light control with bidirectional counting sensors. The design goal is to minimize the cost of electrical energy. The circuits were designed and constructed using various electronics components.

Children, adults, and physically handicapped individuals can all benefit from the Automatic Room Light Controller System since it offers a hands-free lighting control experience. This project required a lot of time in the planning, designing, testing, and execution phases. All things considered, the automatic room light controller system offers a dependable, effective, and adaptable lighting solution for regulating the lighting conditions in a space. The system has the ability to lower energy use, boost comfort, and enhance a room's overall lighting experience.

This project is hereby recommended for use in homes, classrooms, workplaces, or any other enclosed space with the conviction that it simplifies life and lowers energy usage.

It is highly advised for use in living spaces, educational institutions, and meeting spaces. Also, it allows homeowners to experience a luxurious lifestyle that is stress-free for everyone because they do not have to worry about manually turning on and off their lights.

## REFERENCES

- Administrator. (2023, February 25). *Automatic Room Lights using Arduino and PIR Sensor*. Electronics Hub. <https://www.electronicshub.org/automatic-room-lights-using-arduino-pir-sensor/#:~:text=of%20the%20Project>.
- Automatic room light and fan controller with bidirectional visito..* (n.d.). [Www.electronicwings.com](https://www.electronicwings.com/users/abhilasha/projects/27/automatic-room-light-and-fan-controller-with-bidirectional-visitor-counter).
- Automatic Room Light Controller*. (n.d.). Hackster.io. Retrieved March 22, 2023, from <https://www.hackster.io/ashumhr12/automatic-room-light-controller-7f61d5>.
- Automatic Room light Controller with Visitor Counter*. (2013, June 10). [Www.projects.of8051.com](https://www.projects.of8051.com/automatic-room-light-controller-with-visitor-counter/#:~:text=Automatic%20Room%20Light%20controller%20section).
- Automatic Room Lights using Arduino and PIR Sensor*. (2018, January 25). Electronics Hub. <https://www.electronicshub.org/automatic-room-lights-using-arduino-pir-sensor/>.
- EP Ogherohwo. (2018, May 22). *Automatic Room Light Controller with Bidirectional Visitor Counter» ElectroDuino*. ElectroDuino. <https://www.electroduino.com/automatic-room-light-controller-with-bidirectional-visitor-counter/>.
- Greene, R., Anwar, S., & Favier, P. (2019). Microcontroller Based Automatic Room Light Controller and Visitor Counter: Design and Construction. *Journal of Multidisciplinary Engineering Science and Technology (JMEST)*, 6, 2458–9403. <https://www.jmest.org/wp-content/uploads/JMESTN42353243.pdf>
- Guarav Waradkar. (2020, April 21). *Automatic Room Light Controller Circuit and Applications*. ElProCus - Electronic Projects for Engineering Students. <https://www.elprocus.com/know-about-working-of-automatic-room-light-controller-and-applications/>.
- Odiang', M., & a. (n.d.). PROPOSAL ON AUTOMATIC ROOM LIGHT AND FAN CONTROL SYSTEMS. [Www.academia.edu](https://www.academia.edu/7334897/PROPOSAL_ON_AUTOMATIC_ROOM_LIGHT_AND_FAN_CONTROL_SYSTEMS).
- Singh, G. (n.d.). *Automatic Room Lighting*. Engineers Garage. Retrieved March 22, 2023, from <https://www.engineersgarage.com/automatic-room-lighting/>.
- Sinha, S., 172, Sinha, A., Singh, A., Singh, D., Singh, P., Maurya, A., & Singh, M. (2017). Automatic Room Light Controller with Visitor Counter. *International Journal on Emerging Technologies (Special Issue NCETST-2017)*, 8(1), 172–175. <https://www.researchtrend.net/ijet/pdf/44-S-837.pdf>
- The Internet of Things with ESP32*. (2016). Esp32.net. <http://esp32.net/>.